

THE DODO

A CADET PUBLICATION FOR CADETS

20 October 1976

dō-dō (dō/dō), n. pl. -dōs, -dōes. 1. any of several clumsy, flightless, distinct birds of the genera *Raphus* and *Pezophaps*, related to the pigeons but about the size of a turkey, formerly inhabiting the islands of Mauritius and Réunion. 2. Slang. a dullwitted, slow-reacting person. [*Fr* *doude* < *doude* silly] —*do*/*do*-ism, n.



U O D

LOVE IT

OR

LEAVE IT

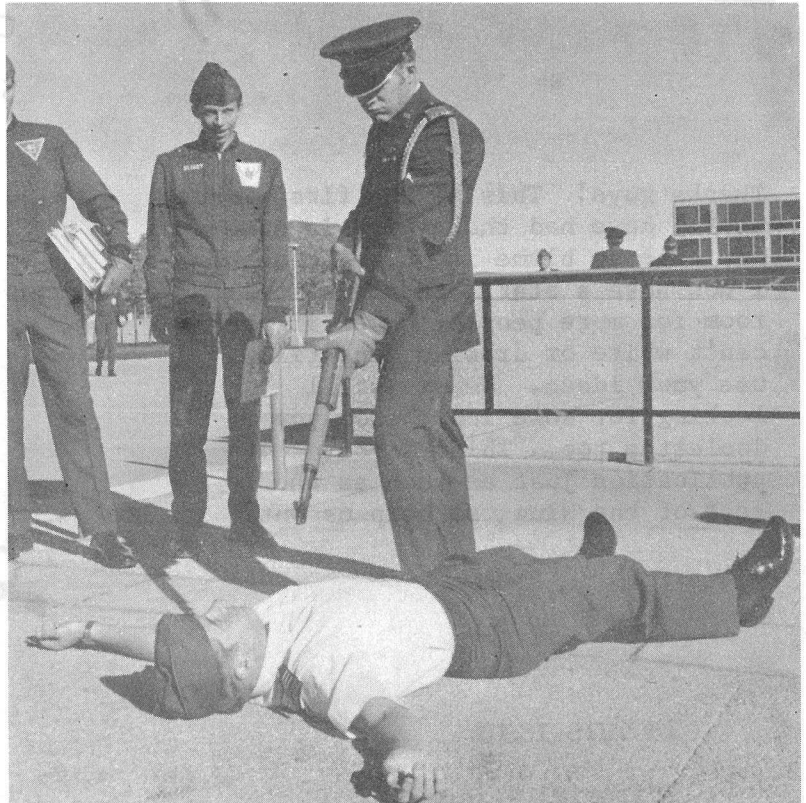

Aerospace - page 2
The Cake Doughnut - page 8

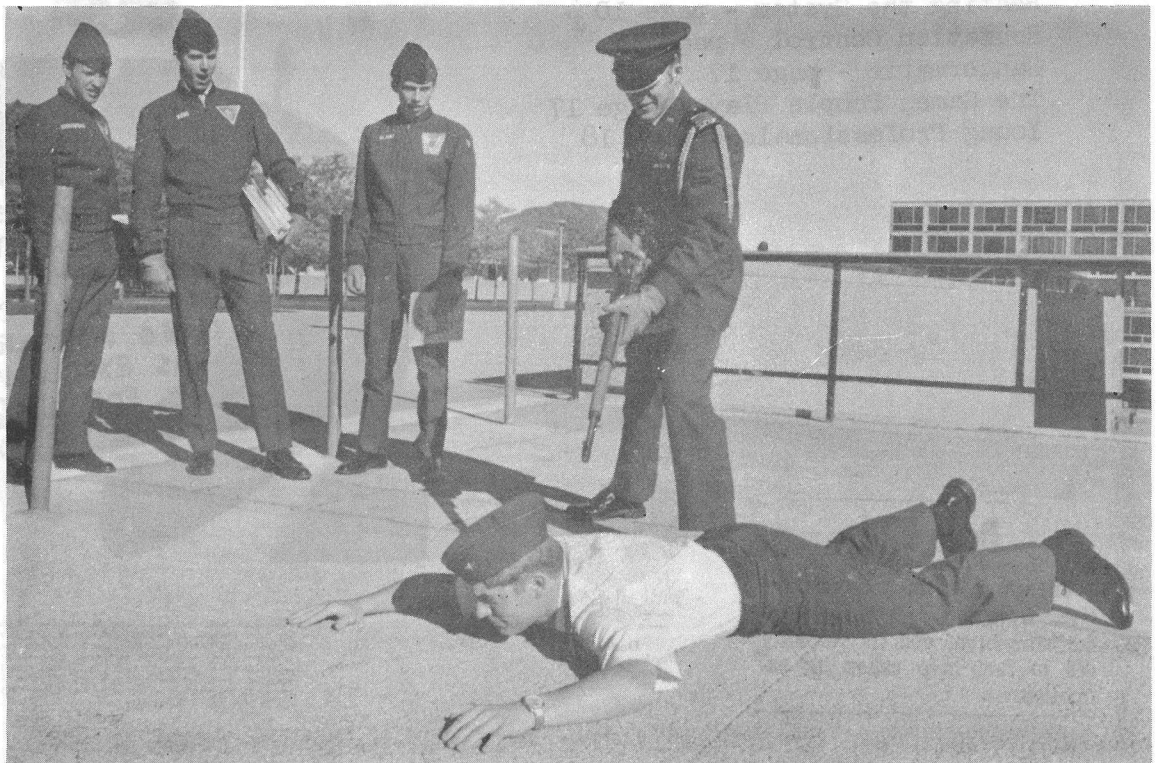

THE Dodo staff

EDITOR	Ron Stevens '77
Ass. EDITOR	Charlie Butler '77
Layout	Bill Lackermann '78
Printing	Larry Largent '78
Cartoons	Doug Morris '78
Satires	John Wagner '79

Thanks guys! This is the first issue that I have had that there is someone else to blame it on. Although I now have a staff, there is still room for more people. Even if you can't write or draw we can still use your ideas. We are still looking for some input from you doolettes too. This is your publication just as much as the rest of the Wing, so help us out!

IN THIS ISSUE

- Editorial - page 3
- AeroSpacemate - page 5
- The Cake Doughnut - page 8
- Beating the System - page 10
- Radiation Control - page 14
- Hangermatic - page 17
- The Games People Play - page 17
- Young Professionals - page 18

Dodo Birds

The name of the dodo was derived from the Portuguese word for simpleton, and its stupidity did in fact help cause its extinction.



Dodo,
Raphus solitarius
(Length 3 ft.)

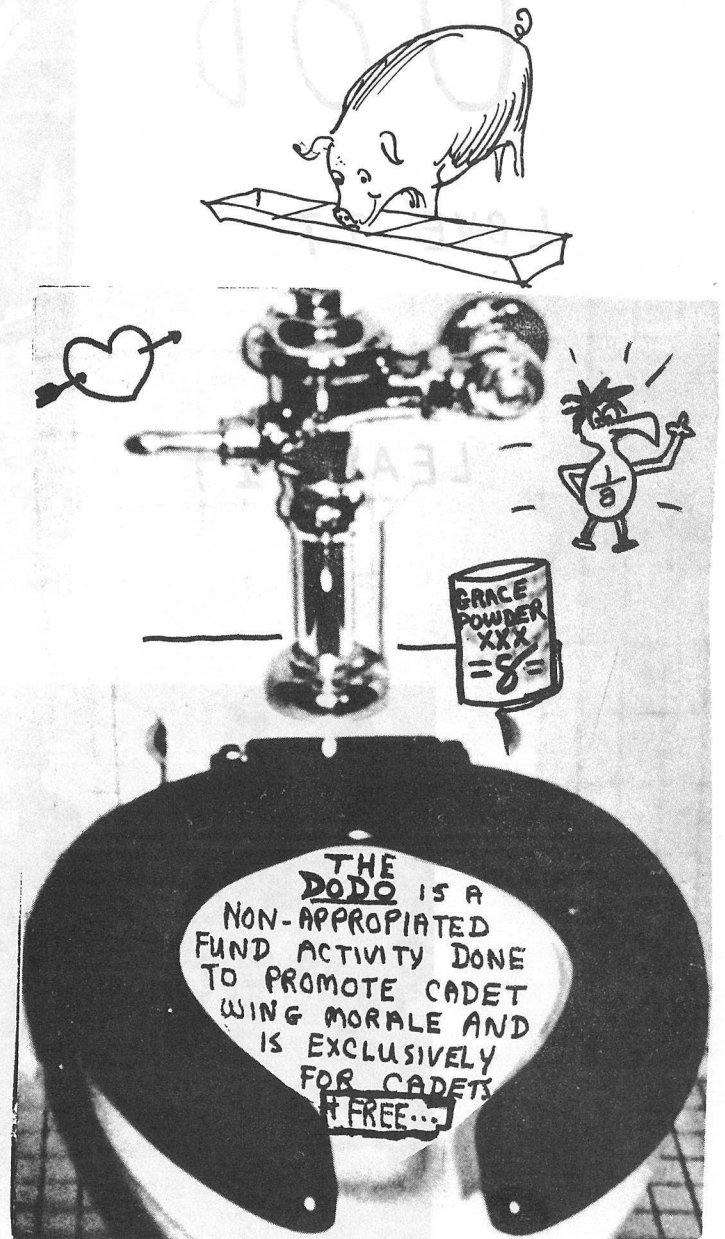

DODO is an unofficial humor magazine published in the interests of cadets at the United States Air Force Academy. It is published by cadets, a group in no way connected with the Department of the Air Force. Opinions expressed by the publishers and writers are their own and are not to be considered an official expression by the Department of the Air Force. The appearance of satirical advertisements in this publication, including inserts and supplements, does not constitute an endorsement by the Department of the Air Force of the products or services advertised. The articles appearing in DODO are fictitious, as are the characters, and any similarity between them and reality is purely accidental.

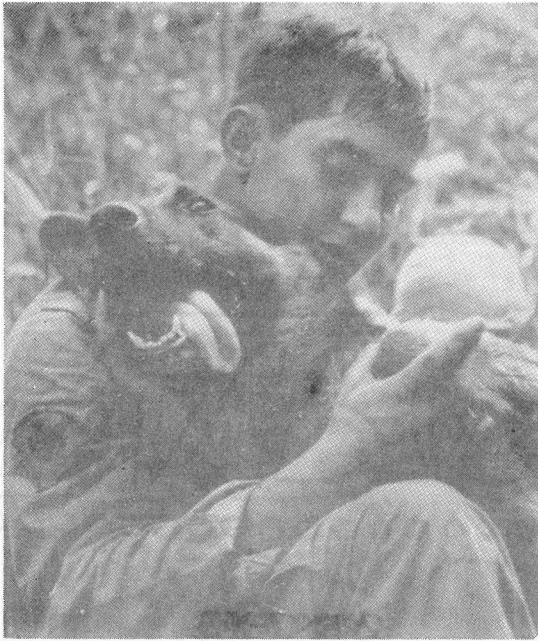

WESTPOINT CADET OBSERVED PETTING DATE AFTER RECENT DANCE AT THE HUDSON HIGH.

EDITORIAL.

If you have noticed a change in the DODO in this issue, it is probably because there was a change. I feel that the purpose of this magazine is to take things at the Academy and present them in a satirical context, and to make fun about anything that we can. The Spacemate is still here, and it won't leave, so all of you that want the old type of DODO still have something to look forward to each time we come out. I really think that you are going to like this issue, because it pertains to everyday cadet life and to subjects which a lot of people don't like to make fun of. I always said, "If you can't take a joke, then"

Ron Stevens

Anyone with ideas or material to submit please contact Ron Stevens in CS-30 or Charlie Butler in CS-13.

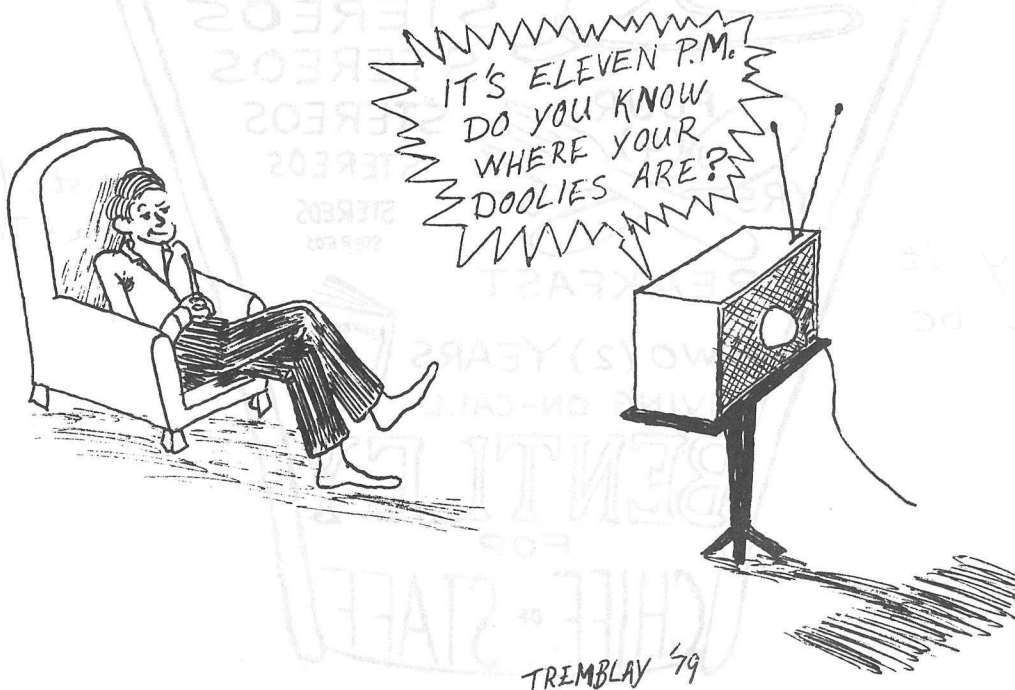

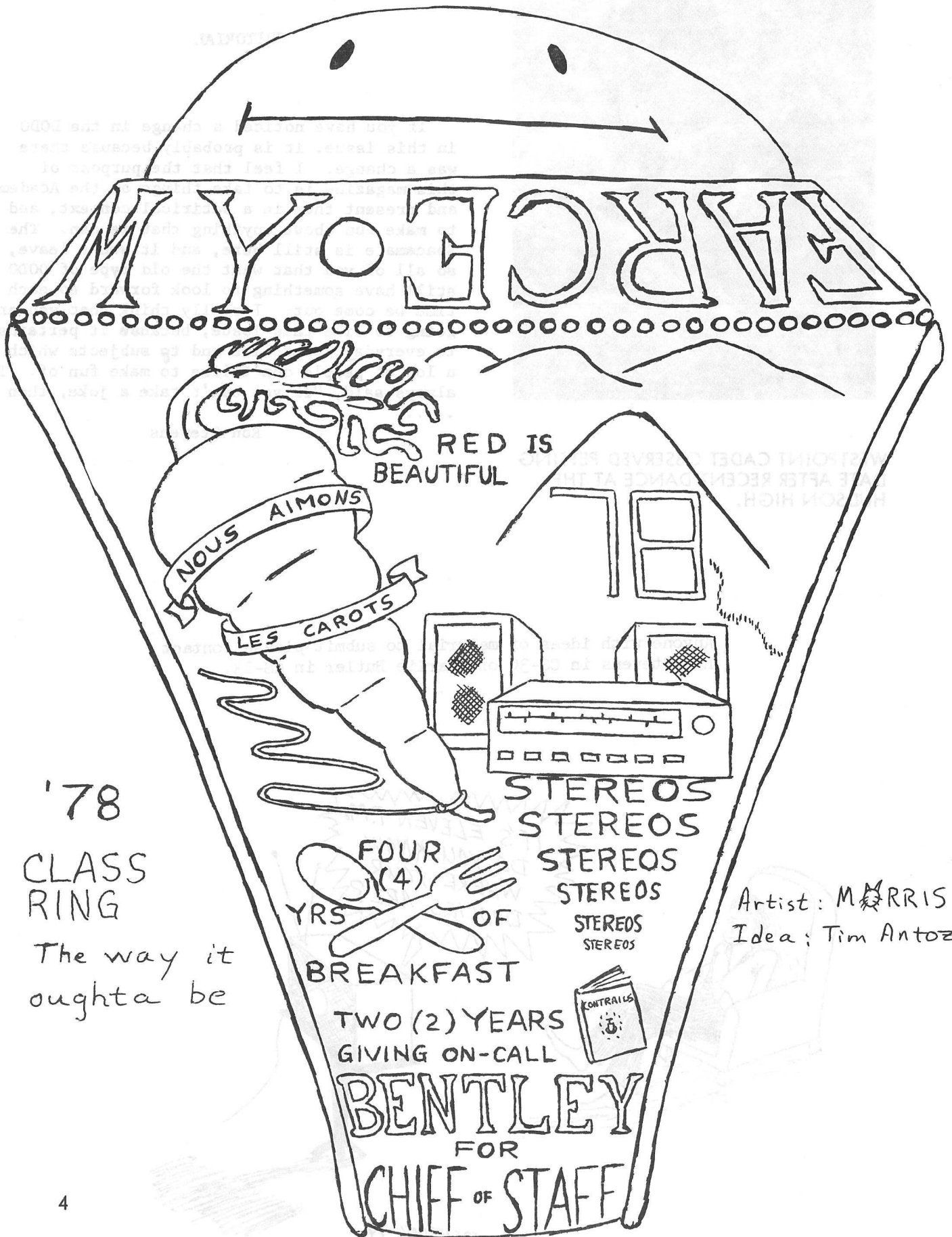

'78
 CLASS
 RING
 The way it
 oughta be

Artist: MARRIS
 Idea: Tim Antozzi

THE DOGMA
AERO-
SUNBATH

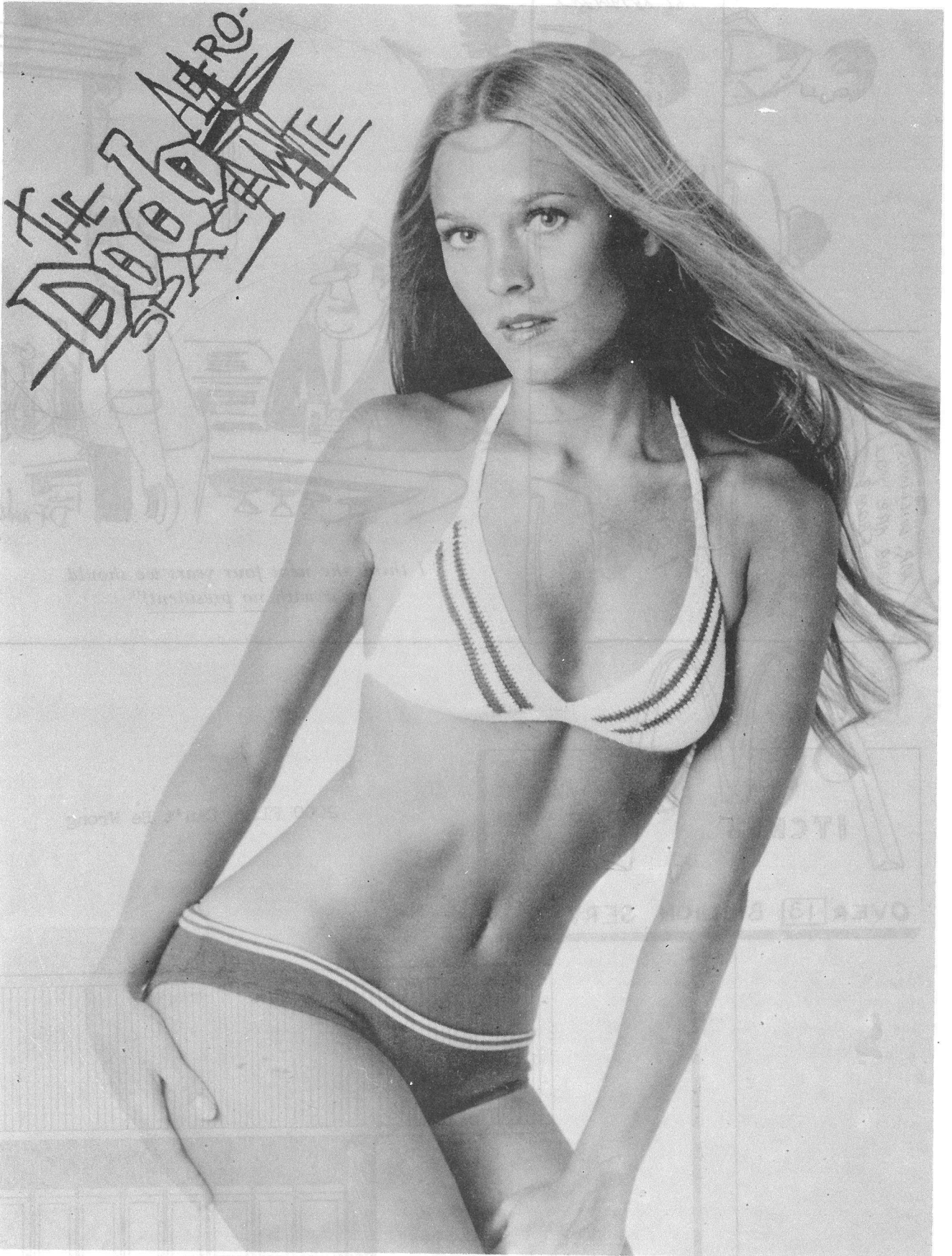

"PLAYBOY"

TREMBLAY '79

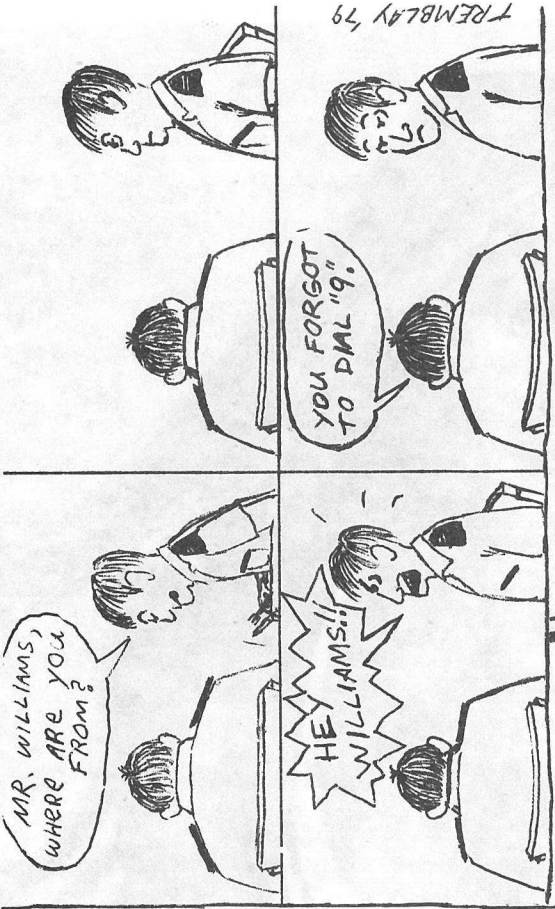

"I think the next four years we should try it with no president!"

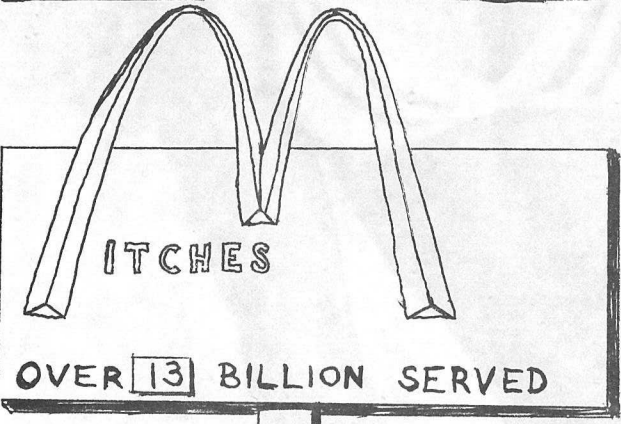

2000 Flies Can't Be Wrong

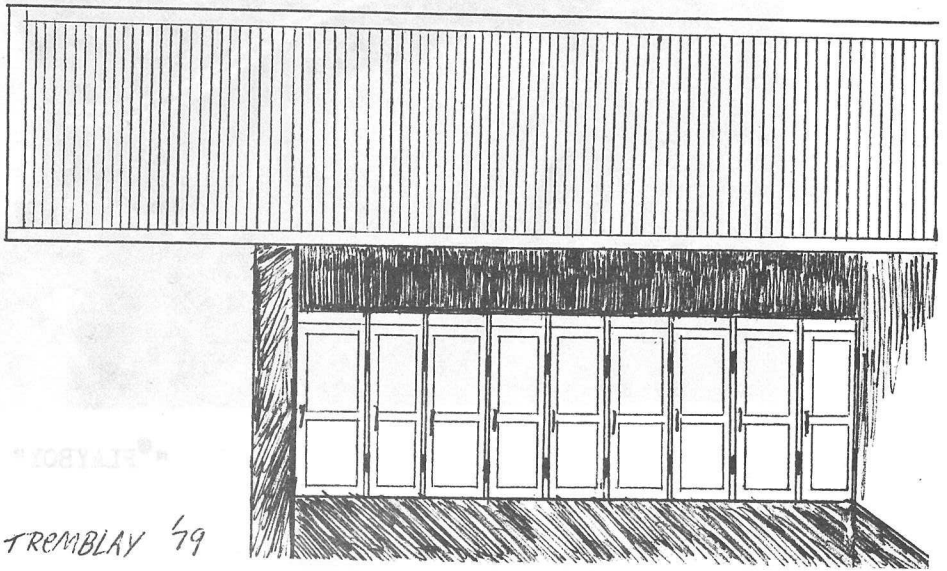

TREMBLAY '79

His shoes are better than mine. I'd better not match with him.

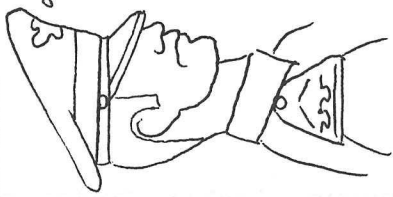

I just know he'll match shoes with me. Mine are gross.

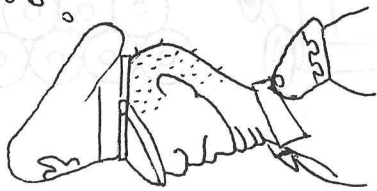

①

His posture and appearance are perfect. I'll find somebody else.

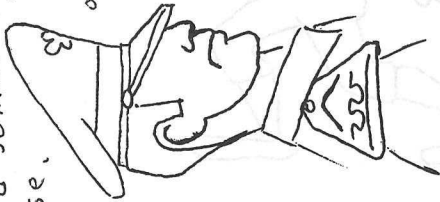

He's taking so long I must really be lousy. Why doesn't he pick on someone else?



③

His chins are in too. I can't get him for that.

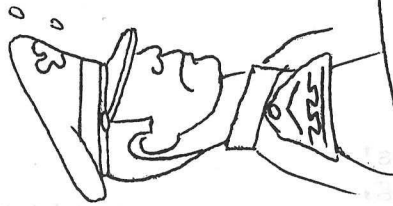

Or he'll tell me to get my chin in. They always tell me that.

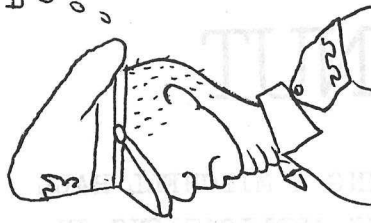

②

PREPARE TO FALL IN!

I'M SAVED! I was beginning to feel silly standing here

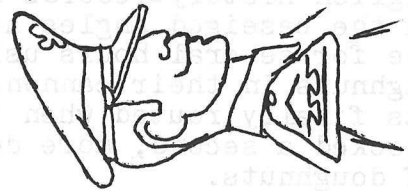

I'M SAVED! I was expecting to get dumped on any minute

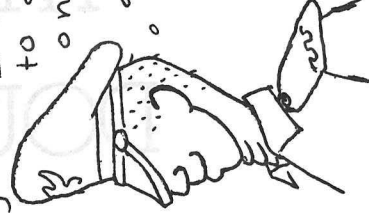

④

MARRIAGE

AT LAST! A CONCISE HISTORY OF . . .

THE CAKE DOUGHNUT

THE CAKE DOUGHNUT, BESIDES BEING A MITCHELL HALL DELICACY, HAS BEEN USED IN MANY APPLICATIONS IN THE OUTSIDE WORLD.....

Early English history records a battle in which the besieged Angles held off the Horde for several hours using only cake doughnuts in their cannon. The Horde was finally routed when the Angles' bakery cooked a second, more devastating, batch of doughnuts.

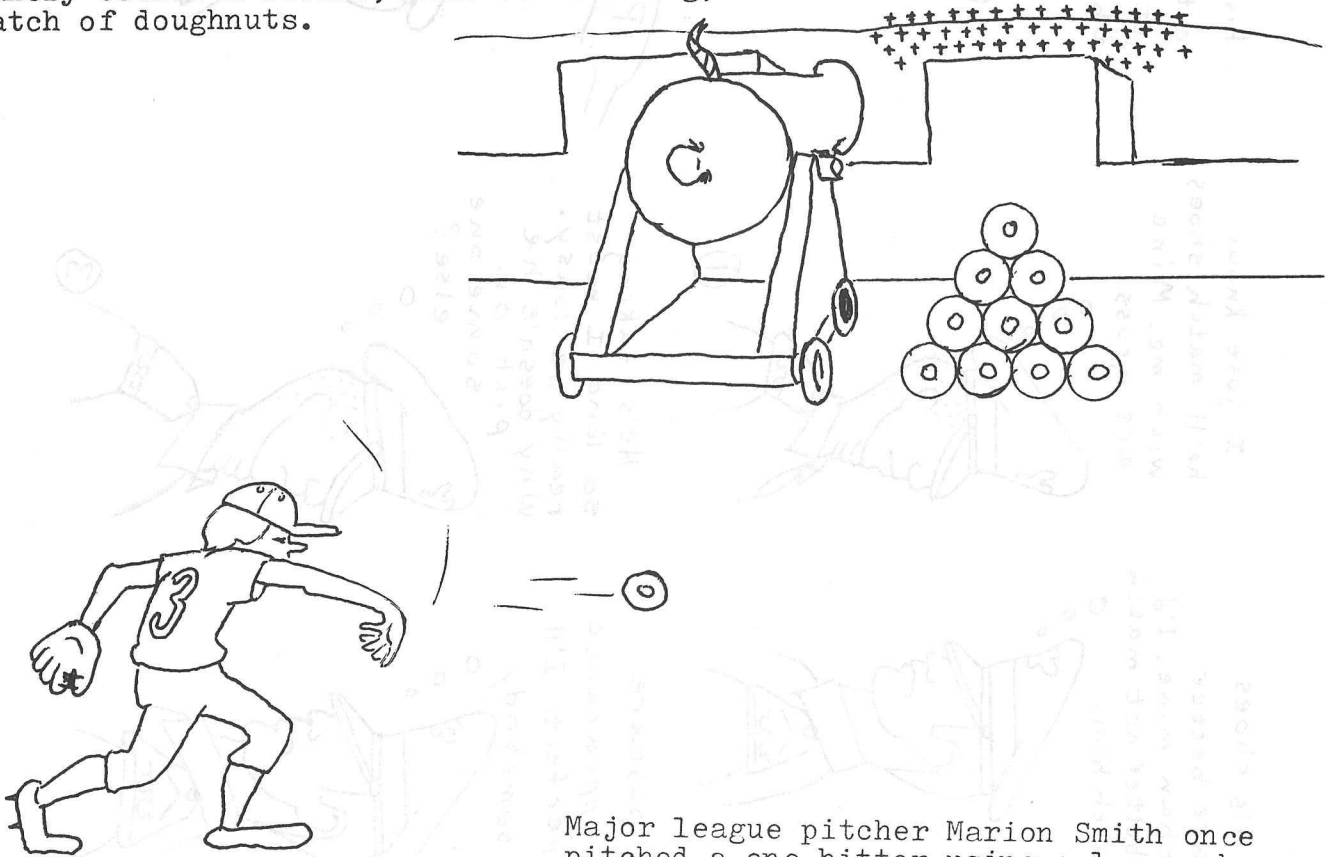

Major league pitcher Marion Smith once pitched a one-hitter using only a cake doughnut. The fact that a doughnut had been substituted for a baseball was discovered when one player's bat splintered upon contact with a pitched cake doughnut.

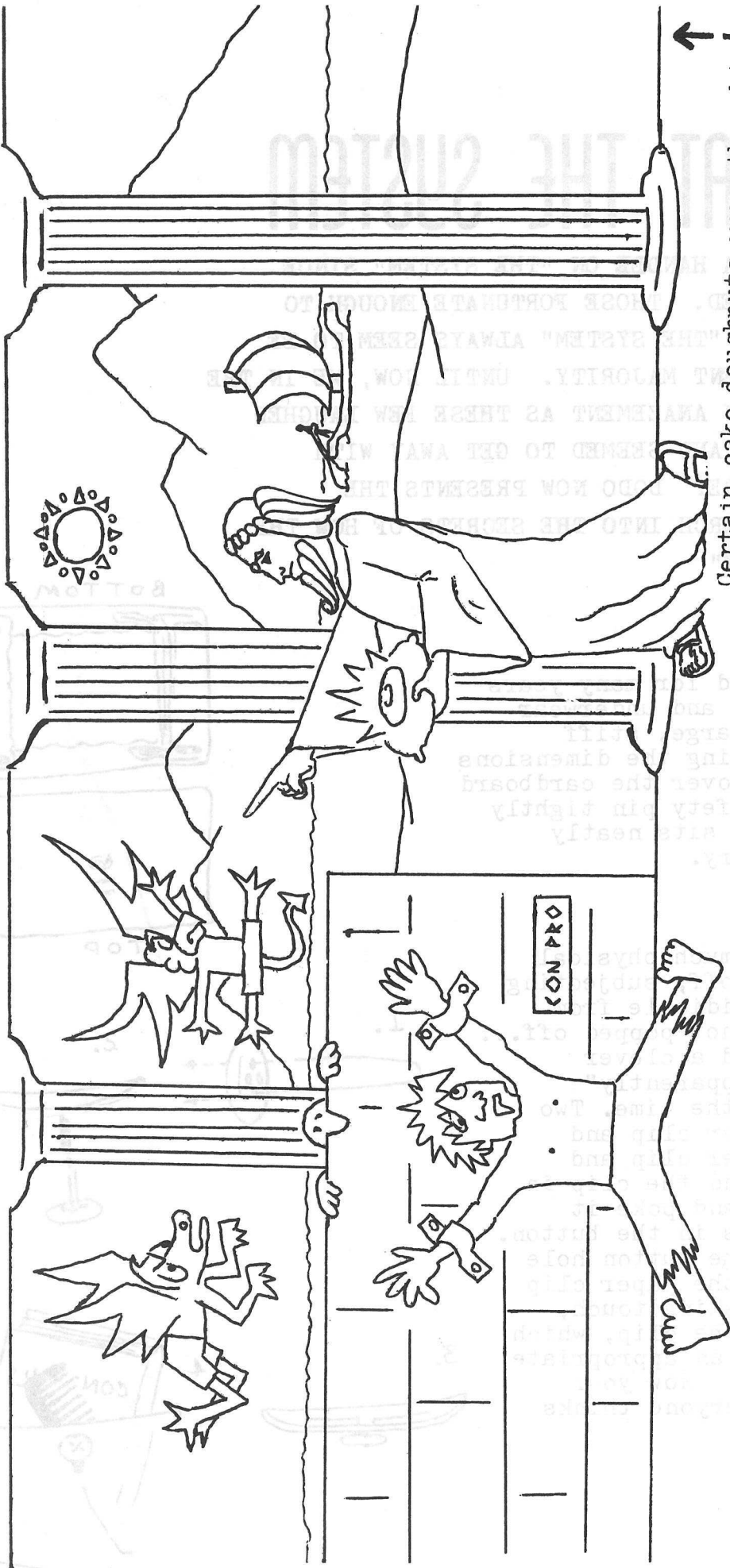

Certain cake doughnuts were thought to have magical powers during Medieval times. Due to its extreme density, the cake doughnut was thought to trap evil spirits and some doughnuts were passed around for centuries.

In more recent times, an astronomer expert on black holes in outer space has done extensive research on the properties of the cake doughnut. The density and composition of a cake doughnut creates a magnetic field in the area of the doughnut. Some cake doughnuts appear black because the intense gravitational field does not allow light rays to be reflected off the glazed surface. Some cadets have reported metal utensils actually warped and bent by a nearby plate of cake doughnuts.



NOW YOU CAN LEARN HOW TO . . .

BEAT THE SYSTEM

CADETS HAVE TRIED TO GET A HANDLE ON "THE SYSTEM" SINCE DAY ONE: FEW HAVE SUCCEEDED. THOSE FORTUNATE ENOUGH TO ENJOY A FLEETING GRASP OF "THE SYSTEM" ALWAYS SEEM TO BE ONE STEP AHEAD OF THE SILENT MAJORITY. UNTIL NOW, WE IN THE RANK AND FILE LOOKED ON IN ANAZEMENT AS THESE FEW LAUGHED AT OUR FOOLISH COMPLIANCE AND SEEMED TO GET AWAY WITH ANYTHING, ANYTIME, ANYWHERE. DODO NOW PRESENTS THE PRODUCT OF MONTHS OF RESEARCH INTO THE SECRETS OF HOW THE SHARPIES "BEAT THE SYSTEM"

This trick has been around for many years and resembles the T-shirt and underwear cardboard trick. Cut a large, stiff square of cardboard matching the dimensions of a laundry bin. Then cover the cardboard with a laundry bag and safety pin tightly in the back. The bag now sits neatly on any size pile of laundry.

Back pocket buttons take much physical abuse and frequently pop off, subjecting the "unbuttoned one" to ridicule from those whose buttons have not popped off... yet. Dodo has encountered a clever scheme to guarantee an "apparently" buttoned back pocket all the time. Two items are required: a paper clip and a button. Uncoil the paper clip and break it in half. Now bend the clip in half in a hairpin shape, and poke it through two diagonal holes in the button. Thread the clip through the button hole in the pocket. Now bend the paper clip ends outward. For a finishing touch, color the silver part of the clip, which is visible on the button, an appropriate color with a magic marker. Now your wallet isn't safe, but everyone thinks you're sharp.

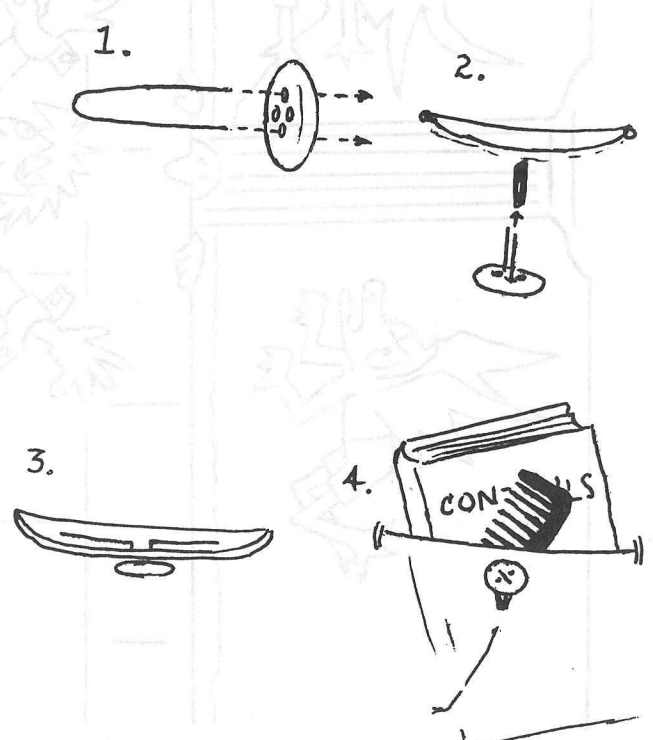
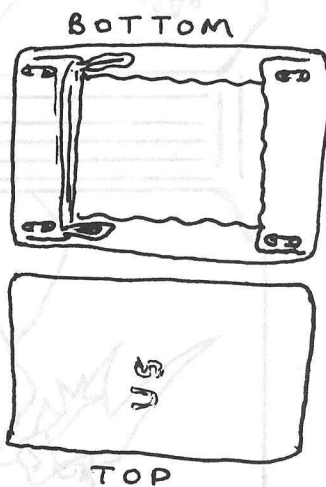

One of the neatest stunts we have seen during this study has to be the "apparently" perfect belt. It requires no adjustment and always looks perfect. To perform the "perfect" belt adjustment, separate the belt buckle from the belt material. Using a sharp instrument, pry the silver tip off of the belt material. Slide the belt material back into the belt buckle, but don't shut the toothed edge yet. Now push the silver tip between the belt material and the buckle where the material contacts the toothed edge. This may require a little work at first, but when the toothed edge is closed, the buckle should present a "perfect belt" all the time. The belt material now locks into its usual place without disturbing the silver tip. The loose end may tend to fray if not cut or trimmed periodically.

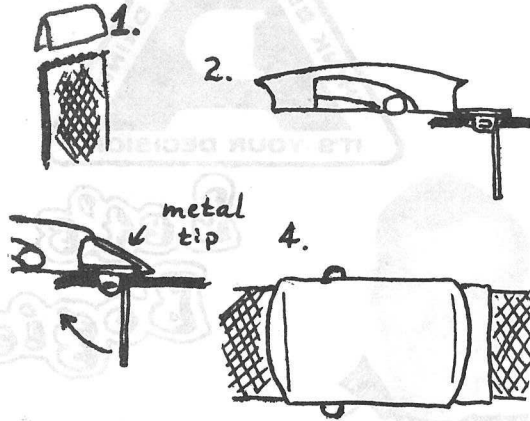

Dodo acknowledges some hesitancy from our sources to print this shortcut, as it could result in further action. With the lighter colors of the "short sleeve alpha" Charlie shirt, the trick is widely known and practiced. Our source goes one step farther with the "parade" shirt: Get out your scissors and find an Alpha shirt the laundry has deemed "worthy of sacrifice!" Cut off the sleeves up to the shoulder. Cut off everything below the third and fourth button. The Alpha blouse now hides everything that shows, keeping the marcher cool and comfortable.

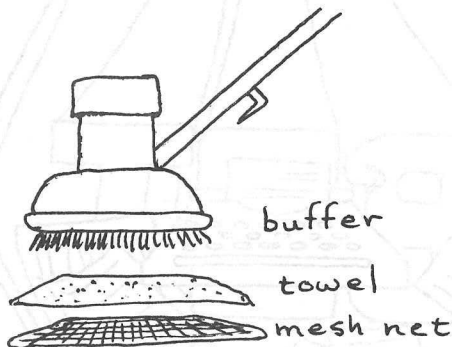

Every cadet professes his or her fool-proof method of whipping a tile floor into a glossy, mirrorlike surface. The average person can learn five different methods by asking five different cadets. Dodo learned of a handy tip that has been confined to only a few squadrons until now. Instead of a towel, next time try using the big laundry mesh net for the final buff. Cover the net with a towel, and buff as usual. The buffer retains its controllability longer because the finer mesh material has less resistance. The finer material also makes for a better shine.

Dodo has come upon a few more stunts which require no elaboration: One cadet handles his own shoe repair by looking out for used shoe taps which wear or fall off and can be seen lying around the terrazzo. Paired with hardware store tacks, the system is faster and cheaper than the shoe store....The hatband over the bill of an alpha cap can be secured by a thin rubber band. Tied on the inside of the sliding hatband loop, the rubber band runs back to the hat screw, and is completely out of sight....One fellow uses a label maker to number his books in order of height. The saves fumbling and "sizing" each morning on the bookshelf.



Let's
Bogie

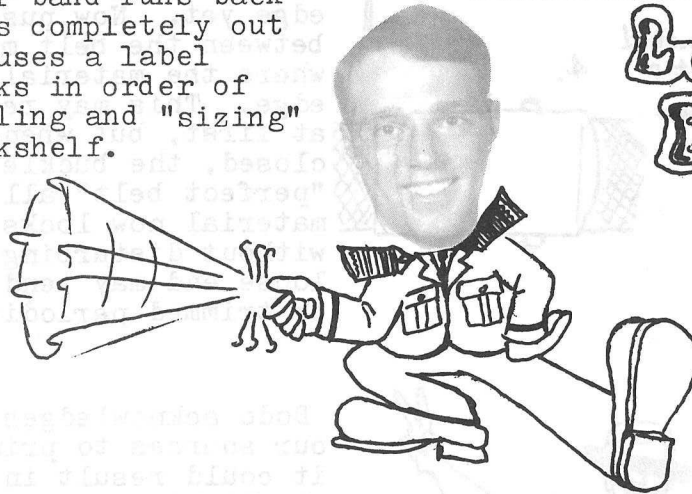

This past summer's BCT patch became the first of its kind to help us remember a leadership option most participants would rather forget. So few cadre members actually saw a BCT patch that DODO feels guilty satirizing that which is not familiar to all. BCT element leaders who suffered through over 25 forms weekly can appreciate DODO artist Doug Morris' sense of humor.

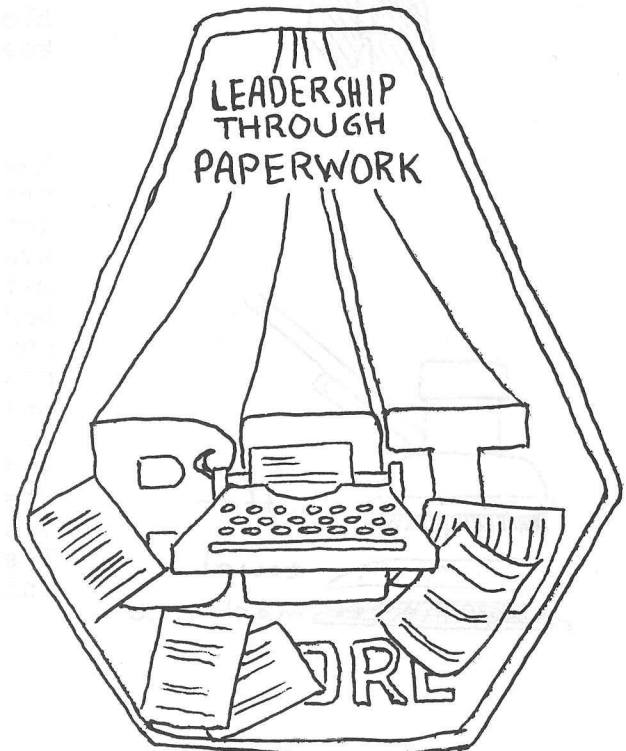
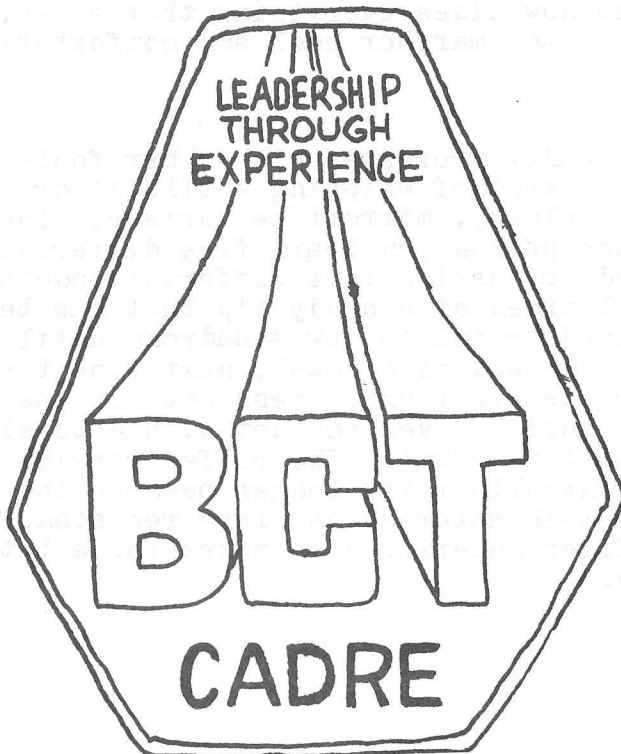



COMING
NEXT ISSUE

AEROSPACE
TOWER
LEAPING

A SHORT COURSE IN RADIATION CONTROL

The basic signal without sufficient screening receives unfiltered emissions from all directions. This results in total distortion and loss of reception and transmission.

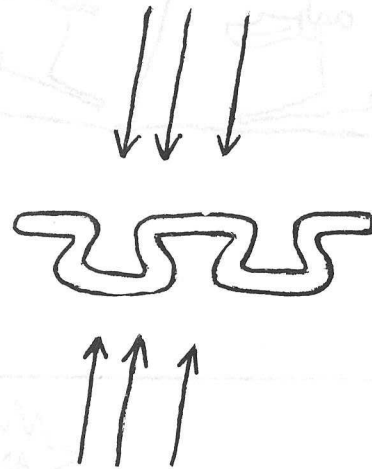

The signal with a single screen provides protection to one side, but still has no significant filtering effect.

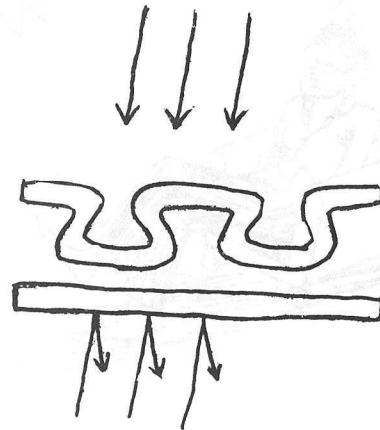

The angular shape of the upper screen deflects many of the emissions, in addition to the lower screen. However, the total protection is still not effective or significant at this point.

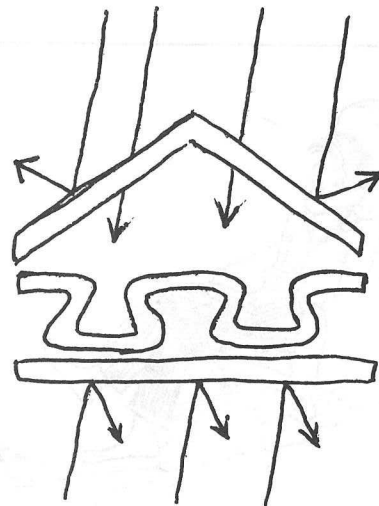

The screening effect becomes useful when at least two angular screens are placed perpendicular and between the source and the basic signal.

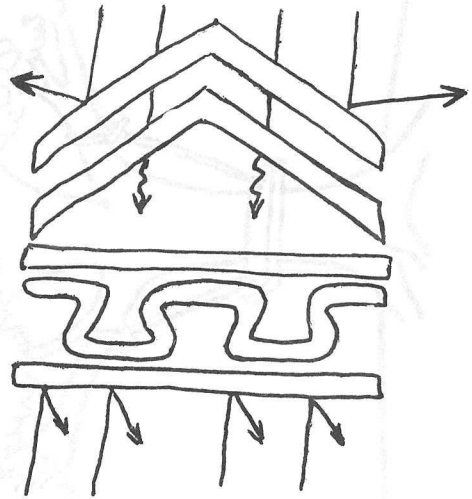

Finally, we see the ultimate screening device in one or more flat surfaces. Though similar to the lower screen, the upper screens are much larger and significant in their overall effect.

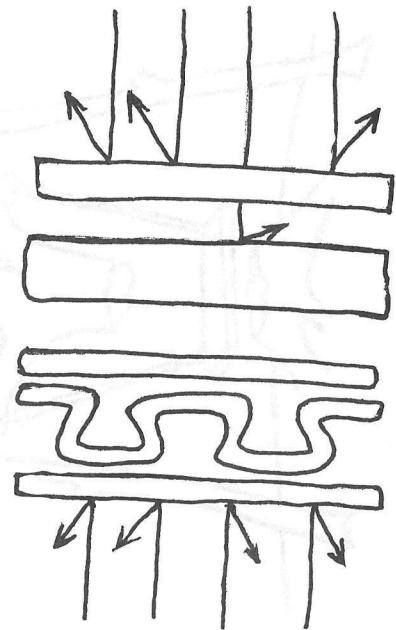

Sir, the waiter is on turnaround.



Our Censor

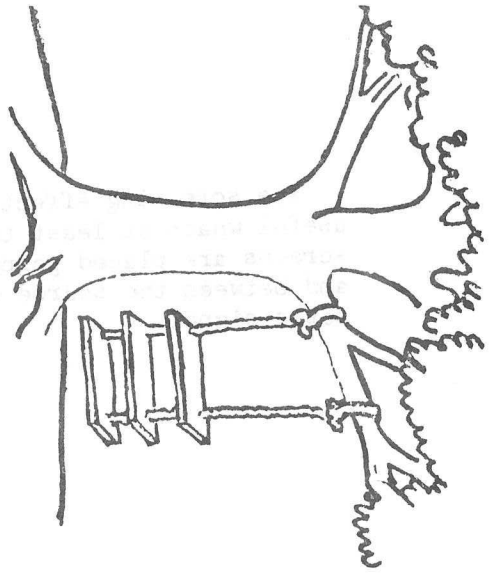

As Proposed by the PROJECT SPONSOR

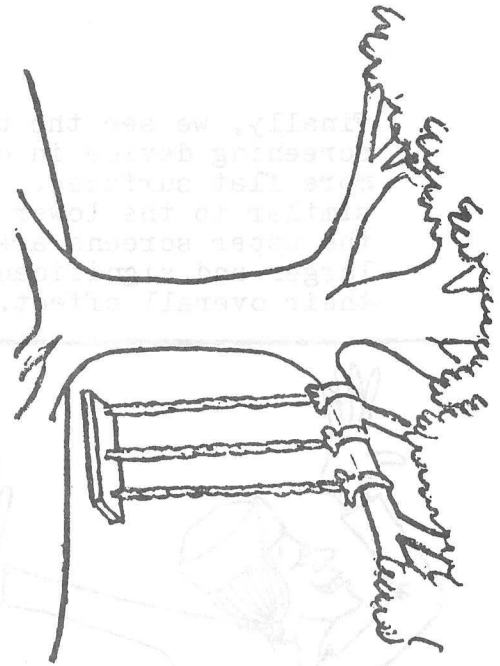

As Specified in the PROJECT REQUEST

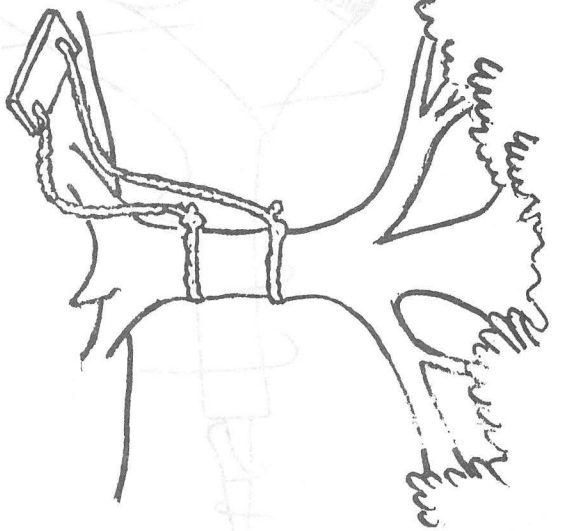

As Designed by the SENIOR ANALYST

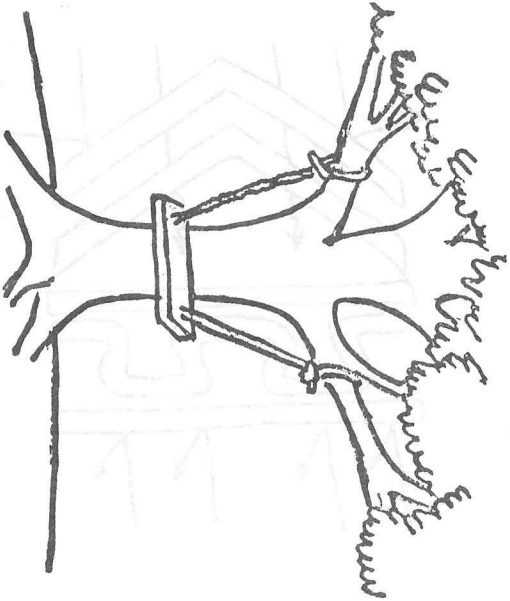

As Produced by the PROGRAMMERS

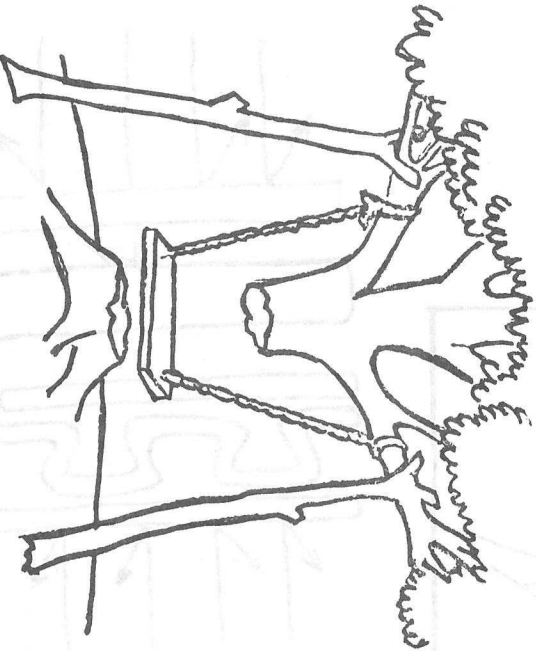

As Installed at the USER'S SITE

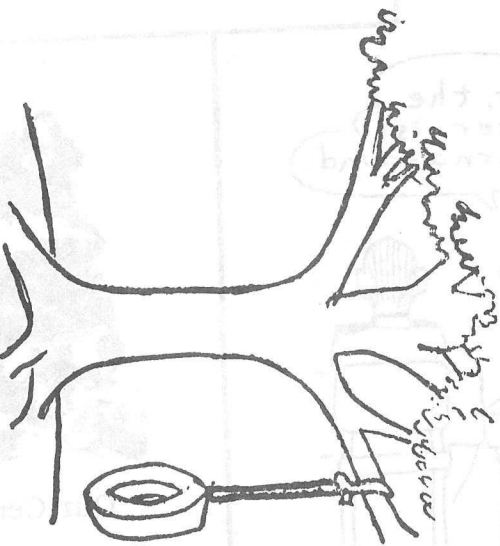

What the USER WANTED

HANGERMATIC IS HERE!

Are you tired of being a ninety pound weakling, do you want the kind of SUPER BODY that girls admire and men respect? Well then try my new two week course and my revolutionary new exerciser, the HANGERMATIC. Not found in any store, the HANGERMATIC used with my SECRET MUSCLE PUMP techniques, will improve your muscle tone and the size of your muscles enormously. In only two short weeks, using the HANGERMATIC for only five short minutes every day, you can increase the size of your biceps by 3 inches, your triceps by 4 inches, your quadriceps by 5 inches, and your parapleges by an incredible six inches.

So, if you want a new and improved body with added slabs of muscle, if you want yard-wide shoulders, a rock hard stomach, huge arms and powerful legs, then send today for your FREE brochure with much more information about my revolutionary new HANGERMATIC. Please enclose \$10.00 to help cover postage and handling costs.

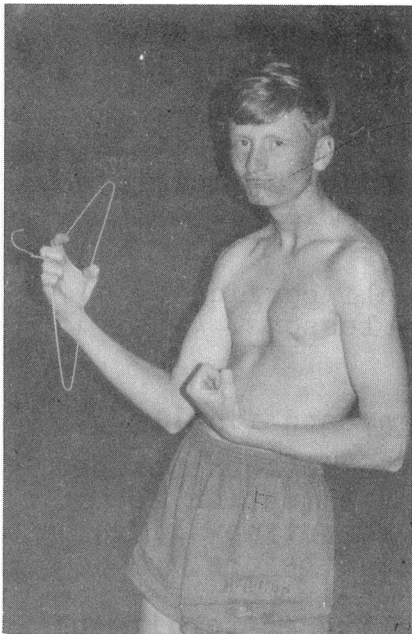

THE GAMES PEOPLE PLAY

In the past few years many crazes have swept the country from Davy Crockett to Zorro, from Rock n' Roll to the twist. And each time American business has stepped into a small fortune peddling coon-skin caps, superman capes, silver bullets, Dick Tracy wrist-radios, and twisting shoes, to mention just a few.

It is about time, I think, that cadets cashed in on their own popularity and began some of their own sales enterprise.

1. Official Air Force Cadet Junior Jump Badge.
2. Be-A-Real-Air-Force-Cadet Kit (Ages 4-10)
Including:
 - 1 - summer uniform
 - 1 - winter uniform
 - 1 - buffer
 - 1 - pad of Form 10's
 - 1 - Olivia Newton John record
 - 1 - Picture of Barbie Benton
 - 8 - Booklets
 - 1) 1001 ways to get out of an IRI and parade
 - 2) 47 new ways to flunk EE
 - 3) How to hide a transistor radio in you parka
 - 4) How to double your privileges in four years
 - 5) How to look awake in ECON
 - 6) Alphabetical listing of known Bogies
 - 7) 25 PDA's your mother didn't tell you about
 - 8) What to do until your class III comes down
 - 1 - map of Loretto Heights showing machine gun implacements, barbed wire fences, secret exits, etc.
 - 1 - Beer can opener
3. Official Air Force Cadet OTF Kit (Ages 6-15) Including:
 - 1 - life-like cadet dummy
 - 1 - pair soft soled shoes
 - 1 - 30 foot rope
 - 1 - fake ID
 - 1 - bottle Jim Beam
 - 1 - car hot-wiring kit

YOUNG PROFESSIONALS

Even as you read this hundreds of ambitious young men at the United States Air Force Academy of Colorado are dedicating themselves to a life of accepting challenge and pursuit of excellence. Whether your goals are increased career opportunities or self-improvement, then this dynamic organization of cadets can help you! As a member of the YOUNG PROFESSIONALS, in just a few short days you will learn to handle yourself in situations that would have been impossible before:

- BUILD** yourself into a tower of teeming strength in just one hour every other day with five simple exercises; pullups, broad jump, push ups, sit-ups, and the 600 yard run.
- LEARN** to be an athletic master in volleyball, badminton, golf, tennis, diving, and UC(the oriental art of ju-jitsu and Kung Fu).
- SPEAK** in front of large groups with self confidence and knowledge in only ten short lessons.
- SLIP** the surly bonds of earth.
- DANCE** skies on laughter silvered wings, and finally...
- LEARN** to become a man...er, person; to meet and exceed the challenge; to look upon each situation as another chance to excell; to seek out new life; to boldly go where no man has gone before.

Now you can become a member of this elite fraternity of aggressive young people. An opportunity like this doesn't come often so act now! The YOUNG PROFESSIONALS will welcome you to the ranks of assertive young people whose commitment to excellence has made them famous in their own time. Please mail the application below today for your membership in the YOUNG PROFESSIONALS. Look at all you receive with each membership in the YOUNG PROFESSIONALS absolutely free:

- * a weekly newsletter, "True Professionalism", written and edited entirely by the YOUNG PROFESSIONALS staff of cadets.
- * an official YOUNG PROFESSIONALS membership card engraved with YOUR name; and an authentic YOUNG PROFESSIONALS T-shirt with "Commitment to Excellence"

emblazoned across the front.

- * YOUNG PROFESSIONALS own monthly magazine, full of news and features of the dynamic, aggressive members of the YOUNG PROFESSIONALS.
- * access to the YOUNG PROFESSIONALS headquarters and facilities located 12 miles north of Colorado Springs, Colorado. This includes dining privileges at the lush, exclusive Cockpit Lounge, reserved for only the YOUNG PROFESSIONALS.

Yes, I feel I'm qualified to become a YOUNG PROFESSIONAL, dedicated to excellence and exceeding the challenge each day:

Rush me each month's exciting YOUNG PROFESSIONALS magazine for only \$6.00 yearly.

Please send me the starter course "COMMITMENT TO EXCELLENCE" and brochure for only \$3.98.

Rush me cassette tapes (\$5.98) records(\$4.98) of the YOUNG PROFESSIONALS Record Company's "Chance to Excell"; written and narrated entirely by cadets.

Name _____

Address _____

Reasons for becoming a YOUNG PROFESSIONAL:

Limited Membership! Enclose check or money order.



I want to be a young professional.

SUITABLE FOR FRAMING

